



# TOPCHEST 4 DRAWER RETRO, ROLL CAB 4 DRAWER RETRO - BLUE WITH WHITE STRIPE

MODEL NO: **AP28104BWS & AP28204BWS**

Thank you for purchasing a Sealey product. Manufactured to a high standard, this product will, if used according to these instructions, and properly maintained, give you years of trouble free performance.

**IMPORTANT:** PLEASE READ THESE INSTRUCTIONS CAREFULLY. NOTE THE SAFE OPERATIONAL REQUIREMENTS, WARNINGS & CAUTIONS. USE THE PRODUCT CORRECTLY AND WITH CARE FOR THE PURPOSE FOR WHICH IT IS INTENDED. FAILURE TO DO SO MAY CAUSE DAMAGE AND/OR PERSONAL INJURY AND WILL INVALIDATE THE WARRANTY. KEEP THESE INSTRUCTIONS SAFE FOR FUTURE USE.



Refer to instructions

## 1. SAFETY

- ❑ **WARNING!** Ensure Health & Safety, local authority, and general workshop practice regulations are adhered to when using this product.
- ❑ **WARNING!** Use caution when handling and assembling the metal components. The metal may have sharp edges or corners, the use of protective gloves is recommended.
- ✗ **DO NOT** open more than one drawer at a time.
- ✗ **DO NOT** step on the drawers.
- ✗ **DO NOT** let children play with the roll cab or top chest.
- ✓ Ensure all drawers are fully closed and the self locking catch is activated, before moving the toolbox.
- ✓ Secure the brakes when rollcab is in the desired position.
- ✓ Keep the work area clean, uncluttered and ensure there is adequate lighting.
- ✓ Keep the mounting frame clean and tidy in accordance with good workshop practice.
- ✗ **DO NOT** use in damp work areas.
- ❑ **WARNING!** The warnings, cautions and instructions referred to in this instruction manual cannot cover all possible conditions and situations that may occur. It must be understood that common sense and caution are factors which cannot be built into this product, but must be applied by the operator.

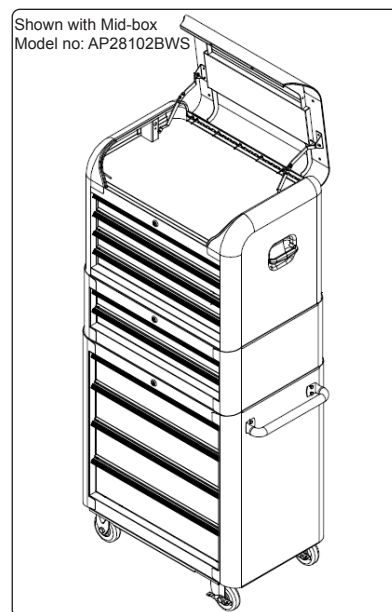

## 2. INTRODUCTION

### 2.1. AP28104BWS

Retro styled topchest with modern day functionality. Features four drawers with ball bearing slides and 'Lift & Latch' drawer pulls preventing inadvertent opening. Chest is further enhanced with opening clam shell top providing additional storage. Retro theme is continued with chrome plated top lid stays, chrome side handles and a blue colour scheme with vinyl white stripes. Drawers and top lid are fitted with drawer liners and lock on one key turn. For use with Model No. AP28204BWS Rollcab and Model No. AP28102BWS Mid-Box to make a complete retro style stack unit.

### 2.2. AP28204BWS

Retro styled rollcab with modern day functionality. Features four drawers with ball bearing slides and 'Lift & Latch' drawer pulls preventing inadvertent opening. Retro theme is continued in a blue colour scheme with vinyl white stripes and stainless steel handle and stylish heavy-duty castors, two with brakes. Drawers are fitted with liners and lock on one key turn. For use Model No AP28104BWS Topchest and Model No. AP28102BWS mid-box to make a complete retro style stack unit.

## 3. SPECIFICATION

Model No:	AP28104BWS	AP28204BWS
Nett Weight:	31.14kg	38.59kg
Overall Size:	700 x 450 x 495mm	
Overall Size with handle:		796 x 460 x 820mm
Overall Size without handle:		716 x 460 x 820mm
Medium Drawer (x4):	570 x 400 x 60mm	
Clam Shell Top:	590 x 430 x 80mm (restricted)	
Large Drawer (x1):		570 x 400 x 105mm
Large Drawer (x3):		570 x 400 x 135mm

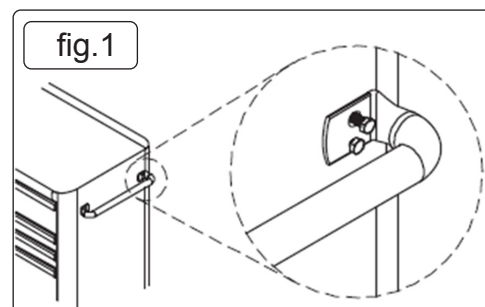

## 4. ASSEMBLY

### 4.1. ROLL CAB HANDLE INSTALLATION.

4.1.1. Position the handle over the holes in the roll cab, attach using the M6 x 12mm hex bolts and tighten securely (fig.1). Assembling the handle first will make it easier to handle the roll cab.

### 4.2. CASTOR INSTALLATION FIG.2.

- 4.2.1. Lay the roll cab carefully on its back, protecting it with a soft mat placed on the floor.
- 4.2.2. Position the two rigid castors at the end opposite the handle.
- 4.2.3. Insert the M8 x 20mm hex bolts through the washers, then through the castors and into the base of the roll cab, tightening securely.
- 4.2.4. Repeat with the two swivel castors on the opposite (handle) end.

**4.3. ROLL CAB AND TOP CHEST CONNECTION.**

- 4.3.1. Place the top chest onto the roll cab.
- 4.3.2. Snap the connectors into the square holes on the back of the top chest (fig.3.).
- 4.3.3. Fasten the connectors with the screws provided.

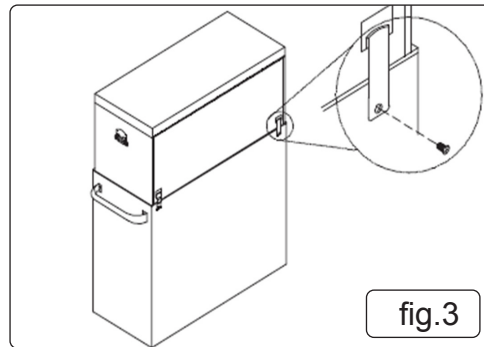
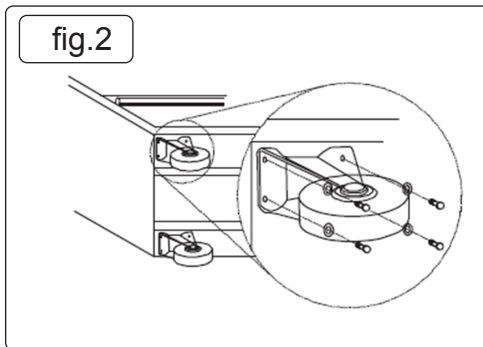

**5. OPERATION**

**5.1. RAISE AND RELEASE DRAWERS.**

- 5.1.1. To open: lift the drawer front whilst pulling it out (fig.4).
- 5.1.2. To close: shut the drawer firmly until the latch engages.
- 5.1.3. If the drawer does not latch, the hook (fig.4) may be misaligned or binding. Bend the hook gently until it is parallel to the drawer edge and engages when closed.

**5.2. TO REMOVE DRAWERS**

- 5.2.1. Pull drawer out almost fully.
- 5.2.2. Locate the black locking levers (figs. 5 & 6).
- 5.2.3. Facing the drawer; lift one lever up (fig.5), and push the other lever down (fig.6).
- 5.2.4. With both levers deployed, the drawer can be pulled out from the slides.

**5.3. TO REPLACE DRAWERS**

- 5.3.1. Extend the drawer runners from the cabinet.
- 5.3.2. Engage the slides on either side of the drawer carefully into the runners.
- 5.3.3. Push the drawer closed squarely until the drawer is closed fully, engaging the locking levers as it goes.

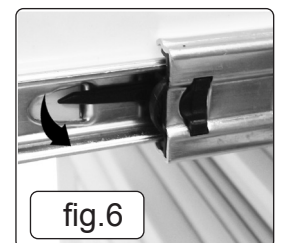
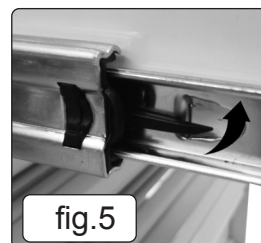
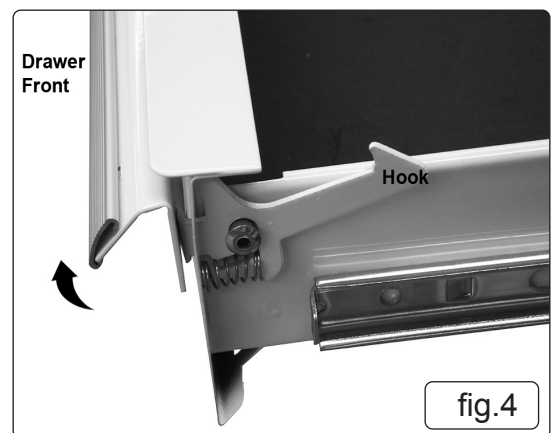

**6. MAINTENANCE**

- 6.1. Lubricate the drawer slides sparingly every six months.
- 6.2. Clean the metalwork periodically with warm water and a mild detergent.
- 6.3. Stubborn grease and oil marks can be removed by using a non-abrasive cleaner.



**ENVIRONMENT PROTECTION**

Recycle unwanted materials instead of disposing of them as waste. All tools, accessories and packaging should be sorted, taken to a recycling centre and disposed of in a manner which is compatible with the environment. When the product becomes completely unserviceable and requires disposal, drain any fluids (if applicable) into approved containers and dispose of the product and fluids according to local regulations.

**Note:** It is our policy to continually improve products and as such we reserve the right to alter data, specifications and component parts without prior notice.

**Important:** No Liability is accepted for incorrect use of this product.

**Warranty:** Guarantee is 120 months from purchase date, proof of which is required for any claim.



**Jack Sealey Ltd t/a Sealey Group**, Kempson Way, Suffolk Business Park, Bury St Edmunds, Suffolk, IP32 7AR UK  
**Jack Sealey (EU) Ltd t/a Sealey Group**, Farney Street, Carrickmacross, Co. Monaghan, A81 PK68 Ireland  
**Tel:** 01284 757500 • **Email:** sales@sealey.co.uk • **Web:** www.sealey.co.uk